



**IGE | IPI**

# **Envisioned. Created. Protected.**

**A Concise Guide to Trade Marks,  
Patents & Co.**

+ pat +

mod.dép.

“Envisioned. Created. Protected. – A Concise Guide to Trade Marks, Patents & Co.” © 2003 Swiss Federal Institute of Intellectual Property (IPI), Stauffacherstrasse 65/59 g, CH-3003 Bern. Twelfth revised edition, July 2023.

Editing and translation by the IPI. Layout and typesetting by Typopress Bern AG, Bern. Photography by Andreas Greber (p. 40), Francesco Rossetti (p. 7 right), Susan Trigg (p. 32) and Stanislav Popov (p. 37). Printed by Vögeli AG, Langnau i. E.

With special thanks to the companies Ricola AG in Laufen, Zenith, branch of LVMH Swiss Manufactures SA, in Le Locle, and Thomas Sutter AG in Appenzell, who allowed us to use their products and logos to illustrate this brochure.

“Envisioned. Created. Protected. – A Concise Guide to Trade Marks, Patents & Co.” is available in German, French, Italian and English. This booklet is free of charge. It can also be downloaded as a PDF under [www.ipi.ch/download-en](http://www.ipi.ch/download-en).

## Contents

<b>Intellectual property</b>	<b>5</b>
Protective rights for innovators and creators	
<b>Intellectual property rights</b>	<b>8</b>
What they are and what they do	
<b>Don't reinvent the wheel</b>	<b>12</b>
Why you should carry out trade mark, technology and patent searches	
<b>Trade marks</b>	<b>14</b>
All about the famous ®	
<b>Patents</b>	<b>20</b>
Helping inventive people	
<b>Intellectual property rights at a glance</b>	<b>22</b>
<b>Designs</b>	<b>28</b>
Protecting aesthetic creations	
<b>Copyright</b>	<b>32</b>
Taking the stage for artists	
<b>Patent attorneys and trade mark consultants</b>	<b>38</b>
<b>The Swiss Federal Institute of Intellectual Property</b>	<b>39</b>

## Intellectual property – Protective rights for innovators and creators

### **Envisioned**

Whoever has bright new ideas ...

### **Created**

... perseveres in refining them and puts them into practice ...

### **Protected**

... should be able to protect their innovations and creations as intellectual property.

### **Intellectual property law**

Unfortunately, the very nature of innovative performance and creative activity leads to them being easily copied and misused. Intellectual property laws, however, offer effective legal protection against this.

## Trade mark protection

Names and logos used to profile or advertise goods, services or companies on the market can be protected by **trade marks** (p. 14–19). Trade mark protection grants the owner the exclusive right to use his or her trade mark to identify goods and services.

The Ricola logo is displayed in a dark green, cursive font with a white outline. A registered trademark symbol (®) is located to the upper right of the word.

## Patent protection

For inventions which considerably improve or newly create a product or a manufacturing process, a **patent** (p. 20–27) can be granted. A patent gives its owner the right to prevent other people from commercially using the invention.

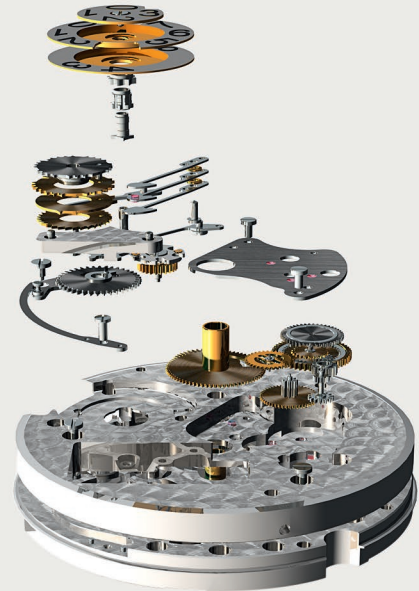

## Design protection

The external appearance of a product, through which it is characterised, can be protected as a **design** (p. 28–31).

The owner of a design right can prevent others from using products with the same or a similar design.



## Copyright

Authors of literary and artistic works are automatically protected by **copyright** (p. 32–37). The copyright owner can determine whether, when, and how his or her work will be used.



## Intellectual property rights – What they are and what they do

“Intellectual property (IP) rights” is a term that includes both industrial property rights (patents, trade marks and designs) and copyright. But what are their main functions?

- **IP rights grant their owners the legal means to exclude other people – usually competitors – from commercially using the products that carry the right.** In particular, the manufacture, use, sale, placing on the market (including in the form of a gift!) and advertising of protected goods or services can be prevented.
- **IP rights turn innovations and creations into a marketable commodity and a company asset.** You can sell, rent (license), lease or pass on IP rights to another person.
- **IP is an important source of information for companies, researchers, developers and creative minds.** Information from the patent, trade mark and design registers as well as from protected topographies is published in the IP databases. Consequently, these databases contain an abundance of data on IP rights.
- **An IP right helps the professional marketing of a product or service and promotes its reputation.** With a strong brand or a superior product, it is easier to recover the sums invested in the development and market launch.

### IP strategies

If you want to optimally protect your goods and services, you should take a strategic course of action and answer some central questions:

- Is protection actually necessary? Is there a threat of misuse by other people?
- Which protection is the best one? Alongside formal protection i.e. the registration of trade marks, patents and designs, there are also informal methods of protection such as secrecy or defensive publishing of inventions.
- What exactly needs protection? An invention, a trade mark or a design? Or all three together? And how should it be protected? Should the sophisticated form of a bottle be protected as a design or the name of a drink as a trade mark?
- How far should the protection go? For what kind of goods or services should a trade mark be registered? Should the patent protect the inventive process or the product?
- In which countries do you want to market your product? In which countries do you need protection? Are you prepared to enforce your rights in these countries too? What is the cost-benefit ratio?
- You should also think about existing IP rights of others: are you infringing the rights of other people? Should you monitor the innovations and creations of your competitors?

### Did you know?

- While copyright protection automatically comes into existence with the creation of an original work, protection for trade marks, patents and designs must be applied for and periodically renewed. These requests are subject to certain conditions and formal regulations. You can find further information in the following sections.
- “First come, first served.” IP rights belong to whoever registers their trade mark, invention or design first.

- Important deadlines such as payments and the maximum period of validity first begin from the date of filing an application. This also includes the so-called priority period, during which an applicant can also apply for a trade mark, an invention or a design to be protected abroad without the risk of being forestalled by others. The length of the priority period varies depending on the IP right: six months for trade marks and designs; 12 months for patents.
- IP rights are granted without any guarantee. In Switzerland, for example, inventions are not examined for novelty. Another person can therefore legally contest a granted

Building up an effective IP strategy requires a well-founded knowledge of the various industrial property rights. It is therefore worthwhile involving a specialist (p. 38).

### The limits of IP rights

Granted IP rights are subject to various restrictions.

- **IP rights expire following a maximum term of protection.** Expired IP rights i.e. those that have been deleted after the maximum period of validity or have been withdrawn, are freely available. Exceptions to this are trade marks which can be renewed as often as required.
- **IP rights are only valid in a certain country (the principle of territoriality).** A trade mark registered in Switzerland is therefore only protected in Switzerland. If the trade mark should also be protected in other countries, then you must register it there too. In most cases, even so-called regional or international registration proceedings merely result in purely national autonomous IP rights. Therefore others are, in principle, free to help themselves to trade marks, inventions or designs outside of the area of protection.
- **Generally, only the commercial exploitation of an invention or creation is protected.** Therefore, a patented object may be used privately or for research purposes without the permission of the patent owner, for example. However, there are limits set with regards to private use – in particular regarding the import, export and transiting of pirated products.

IP right at anytime. The court must then decide on whether or not it is legally valid. With trade mark protection, the owner of an earlier trade mark may file opposition to a new trade mark during the three months following the latter's publication in which he can claim that there is a danger of confusion with his earlier trade mark. It is therefore important to determine whether all criteria for protection have been fulfilled before applying for protection of inventions, trade marks or designs.

- **The scope of protection is precisely defined.** There are clear regulations that define the scope of protection for every IP right. For example, a trade mark is not protected in general but only for those classes of goods and services for which it has been registered.

### Warning against dubious offers

Owners of trade marks, patents and designs sometimes receive offers or invoices for useless entries in registers and directories. As entries in private registers or directories are legally ineffective, we strongly advise against their use. In Switzerland, only entries in the IP registers maintained by the Swiss Federal Institute of Intellectual Property are legally binding. Also problematic are unrequested offers for the expansion and extension of protection rights. Monitor critically who you empower to administer your protection rights and do not authorise any unknown person. Whoever signs the often official-looking documents without critical examination or pays the relevant invoices could be in for an unpleasant surprise.

- As a prerequisite for novelty, patents and designs should undoubtedly be registered before their release into the public domain (for example, by selling, at an exhibition fair, or on the internet).
- Potential conflicts with the rights of other people are not examined for during the registration of an IP right in Switzerland. We therefore recommend that you clarify this risk with a specialist (p. 38).

## Don't reinvent the wheel – Why you should carry out trade mark, technology and patent searches

Trade marks, patents and designs are often filed for creations that already exist. A prior analysis can help to avoid unnecessary investments and duplications in the development.

### IP registers are a primary source of information

The registers in which IP rights are registered contain an abundance of information on technical inventions, protected signs and designs. For instance, patent documents that are easily accessible electronically are an integral part of the technical knowledge available worldwide. You can use this knowledge for various purposes:

- In Switzerland, inventions undergoing the patent application process are neither examined as to whether the invention is new nor for its inventiveness. It is therefore recommended to personally clarify these two requirements, for example, by researching patent databases. If a patent application has already been filed, you can request a search by the IPI (p. 25).
- When a trade mark is examined, there is no check to see whether identical or similar IP rights such as trade marks, company or domain names already exist. This must be clarified beforehand by the applicant – if need be with the support of a specialist (p. 38).
- A trade mark and patent search can also clarify whether your product infringes an already existing IP right.
- Targeted searches on the prior art or on existing trade marks in a particular product environment, for example, give a valuable basis for decisions in the research, development and creation phase. For example, they allow you to assess the patentability of an invention and thus avoid time-wasting and duplicate developments.
- With searches, you can also check and monitor IP rights, analyse a competitor or a specific branch as well as identify trends at an early stage.

Our “Assisted Patent Search” offers those with little experience an introduction to patents in return for a small fee. As part of this service, we also explain the principles of trade marks and designs, as required, and carry out a joint basic patent search.

Further information on the possibilities of tailor-made trade mark and patent searches as well as addresses of providers can be found at [www.ipi.ch/trademark-searches](http://www.ipi.ch/trademark-searches) and [www.ipi.ch/patent-searches](http://www.ipi.ch/patent-searches).

### Preliminary information from free databases

Free databases are available on the internet in which you can carry out basic searches on IP rights. These include:

- [www.swissreg.ch](http://www.swissreg.ch) – contains registered IP rights in Switzerland including information on the legal status
- [www.wipo.int/madrid/monitor](http://www.wipo.int/madrid/monitor) – allows for the search of international trade marks that are protected in Switzerland
- <https://worldwide.espacenet.com> – contains more than 140 million patent documents worldwide

**Beware!** These databases are not professional search tools. Therefore, searches in free databases cannot substitute a professional search.



## Trade marks – All about the famous ®

### What is a trade mark?

In the legal sense, a trade mark is a sign that is capable of distinguishing the goods or services of one business from those of other businesses.

### Why protect using trade marks?

Trade marks are a key distinguishing feature for goods or services. A lot of time and money are often invested in their creation and maintenance so they therefore represent valuable capital. You stand out from your competitors with a trade mark.

### What are the practical advantages?

Trade mark protection grants the owner the exclusive right to use his or her trade mark for identifying goods and services. This right can be passed on through licensing or sale, for example. The trade mark owner can prevent others from using a similar or identical sign for similar or identical goods or services provided that there is a risk of confusion.



### Types of trade marks

The following can be protected as a trade mark:

- Words (e.g. Breitling)
- Slogans (e.g. Red Bull's "It gives you wings")
- Letter combinations (e.g. ABB)
- Number combinations (e.g. 501)
- Graphic representations (e.g. the SBB logo)

or a combination of these elements. Acoustic melodies (e.g. the Ricola jingle) can also be protected.

### No protection

Your sign must be able to be recognised as a reference to a certain company. This is not the case with descriptive signs such as 4WD for vehicles or M8 for bolts, for example. If competitors are dependent on using a generic term for a sign (such as WATERPROOF for clothing) it may not be protected as a trade mark.

As a rule, individual colours cannot be protected. Exceptions to this are colours that have come to be accepted as being distinctive and have gained the character of a trade mark through everyday use (for example, the

### Criteria for protection

- In the legal sense, all graphic representations of signs can be trade marks provided that they are distinctive. The deciding factor for judging distinctiveness is the overall impression made by a trade mark.
- A trade mark may not be descriptive i.e. it may not contain any indications concerning the properties, the quality, the type or place of its production or the intended purpose or value of the product (for example, "apple" may not be used as a trade mark for fruit but can be protected as a trade mark for a computer manufacturer).
- A trade mark may not make any misleading claims regarding its origin, its properties or the quality of the product or service, for example (see also "Indications of source" on page 18).
- A trade mark may not violate public order or public morality. This means that a sign may not offend ethical, moral or religious sensibilities (including minorities).

colour lilac for Milka chocolate – see also “Trade marks that have acquired distinctiveness through use” on page 18).

In addition, your sign must not be deceptive with regards to geographical origin, for example. Signs that violate the law or public morality can also not be protected.

National and foreign coats of arms may only be used as trade marks by institutions and companies directly affiliated with the government (i.e. the Confederation, the cantons, etc.) and to whom a specific coat of arms has been attributed.

### Period of protection

A trade mark is protected from the date of filing for a period of ten years. Protection can then be renewed for a further 10 years as many times as required.

### Applying in Switzerland

Do you want to register your trade mark? You can apply to register a trade mark online at <https://e-trademark.ige.ch>. The application consists of an index of goods and services for which you want to use the trade mark as well as an image of the trade mark. Following its registration, the trade mark is then published on [www.swissreg.ch](http://www.swissreg.ch).

### Does a trade mark infringe the rights of others?

It is strongly recommended that you carry out a prior search for trade marks, company or domain names as we do not examine for this criterion during the registration procedure. You can find further information on trade mark searches on page 12 and at [www.ipi.ch/trademark-searches](http://www.ipi.ch/trademark-searches).

### Protection in other countries

Several options are available for the international registration of a trade mark.

- **Applying directly to the country concerned**

Be aware that the legal basis, filing formalities as well as examination and granting procedures vary from country to country.

- **The Madrid System**

This application procedure makes it possible to extend the trade mark protection granted under Swiss law to other contracting states or organisations under the Madrid System. An application for the international extension of protection must be made to the IPI.

- **Several countries with one application**

By filing one single trade mark application with the European Union Intellectual Property Office (EUIPO) in Alicante, Spain (<https://euipo.europa.eu>), you can protect your trade mark in the entire EU territory with a community trade mark. Under the Madrid System, an extension to protection in the countries of the European Union can also be applied for.

We recommend that you discuss trade mark protection abroad and the best filing strategy with a specialist (p. 38).

### Did you know?

- When the name of a company is registered in the Swiss Commercial Register it is not automatically protected as a trade mark. If you want to use the company name to identify products, it can be worthwhile to protect this name as a trade mark.
- A trade mark must also actually be used within the five years following its registration.
- Whoever imports counterfeit brand products for their own personal use risks that the goods will be seized by customs.

## Alternatives to trade mark protection

The identification of your own goods or services without the use of trade mark protection is also possible. However, it is extremely difficult to prevent others from using your sign without trade mark protection.

### Special types of trade marks

- **Trade marks that have acquired distinctiveness through use:** Descriptive signs can attain protectable status if they have achieved recognition in the market as being a trade mark for the goods or services of a particular company. In trade mark jargon, this is called “acquired distinctiveness” (e.g. Coca-Cola for alcohol-free drinks).
- **Trade marks that have become generic through use:** Trade marks can become designations for entire product classes through years of market presence and therefore lose their protective status (for example, “hoover” for vacuum cleaners).
- **Famous trade marks** such as Nestlé or Nike enjoy protection under certain conditions for classes of goods and services they are not even registered for.
- **Internet domain names:** There are various registrars responsible for registering .ch and .li domain names. You can find a list on the SWITCH Foundation’s website at [www.nic.ch](http://www.nic.ch). Domain names can also be registered as trade marks.
- **Indications of source:** Indications of source show the geographical origin of goods and services. A distinction is made between direct indications of source (e.g. Swiss chocolate) and indirect indications of source (e.g. William Tell chocolate).

Direct indications of source are descriptive and cannot be protected as trade marks. If a sign contains elements of distinctive character in addition to a direct indication of source, it can be registered in the trade mark register, provided that it is not clearly misleading. For example, a trade mark with a «Switzerland» element cannot be protected for goods from France.

- **Geographical indications (GIs):** Geographical indications show that a given quality, a particular reputation or another property of certain goods is due primarily to their geographical origin. Examples of geographical indications are protected appellations of origin (PAO) and protected geographical indications (PGI): these are specially protected indications of source that are entered in a register, such as *Tête de Moine* (PAO) and *St. Galler Kalbsbratwurst* (PGI). The products to which they refer must meet the requirements set out in a detailed product specification. The register for geographical indications for agricultural products is maintained by the Federal Office for Agriculture, and the register for non-agricultural products is maintained by the IPI. PAOs and PGIs may also be registered as geographical marks.
- **How Swiss does a product need to be to be labelled as such?** The Swiss cross may be used for advertising purposes for Swiss products and services that fulfil the criteria for determining origin set out in the Trade Mark Protection Act. The coat of arms, however, remains reserved for public bodies.



## Patents – Helping inventive people

### What is an invention?

In the legal sense, an invention is something that uses technology to solve a technical problem such as the removal of a cork from a bottle using a cork-screw, for example.

### Why protect inventions?

Patents are rewards and incentives for research and development. They encourage technical innovation and contribute to the growth and spread of technical knowledge. They are proof of the innovative strength of an enterprise and allow it to secure the use of its invention in a highly competitive market.



### What are the practical advantages?

A patent gives its owner the right to prevent others from commercially using his or her invention (e.g. manufacturing, selling or importing). However, the patent owner may transfer the rights to someone else either by selling the patent or through licensing agreements.

### Not protected

Ideas, concepts, discoveries, scientific theories and mathematical solutions, algorithms, game rules, lottery systems, teaching methods and organisational work flows, diagnostic procedures, therapies and surgical procedures (on either humans or animals), plant varieties and animal breeds are not patentable.

Computer programs as such are also not patentable; they are protected under copyright. Inventions which depend on a computer program, however, are patentable (e.g. electronic control systems). Also excluded from patentability are inventions whose utilisation would violate public order or public morality (for example, certain biotechnological inventions).

### Criteria for protection

Inventions must fulfil the following criteria in order to be patentable:

- Novelty – an invention is novel when it is not already part of the prior art. Any knowledge which is publicly accessible in any form, in any part of the world, before an application for a patent has been filed, is considered prior art.
- Industrial applicability – the invention must be able to be made or used in any kind of industry, including agriculture.
- Inventive step – the invention must not result from the prior art in an obvious way and thus be trivial for a person skilled in the art. Unexpected features of a product or the refutation of a prejudice (i.e. “xyz can’t be done”) are often indications that there is an inventive step.

## Intellectual property rights at a glance

	Trade mark protection	Patent protection	Design protection	Copyright <sup>1</sup>
<b>What is protected?</b>	Registered signs from misuse by others	Inventions i.e. new technical solutions to technical problems	Forms i.e. the exterior appearance of an object	Works of literature and art (including computer programs)
<b>How does it become protected?</b>	Registration in the trade mark register	Granting of the patent	Registration in the design register	Automatically at the moment of creation
<b>Minimum requirements</b>	<ul style="list-style-type: none"> <li>Does not infringe on others' rights</li> <li>Distinctive</li> <li>Not descriptive</li> <li>Is contrary to public order or public morality</li> </ul>	<ul style="list-style-type: none"> <li>Novel</li> <li>Industrially applicable</li> <li>Inventive step</li> <li>Disclosure of invention</li> </ul>	<ul style="list-style-type: none"> <li>Novel</li> <li>Overall impression must clearly differentiate from existing forms</li> <li>Is contrary to public order or public morality</li> </ul>	Literary and artistic creations of the mind that possess individual character (photographs are protected regardless of whether they have individual character)
<b>No protection for</b>	<ul style="list-style-type: none"> <li>Simple signs</li> <li>Specific designations</li> <li>Laudatory indications</li> <li>Misleading signs</li> <li>Coats of arms and other protected signs</li> <li>Etc.</li> </ul>	<ul style="list-style-type: none"> <li>Animal breeds, plant varieties</li> <li>Diagnostic, therapeutic or surgical procedures on humans or animals</li> <li>Use in keeping with public order or public morality</li> <li>Certain biotechnological inventions</li> </ul>	<ul style="list-style-type: none"> <li>Purely technical functions</li> <li>Ideas and concepts</li> <li>Anything that violates federal law (e.g. protection of coats of arms) and treaties</li> </ul>	<ul style="list-style-type: none"> <li>Content (ideas and concepts)</li> <li>Laws and official decrees</li> <li>Decisions by authorities</li> <li>Means of payment</li> <li>Patent documents</li> </ul>
<b>What are the exceptions?</b>	When not used as a trade mark	Private use, research and teaching		Private use, citations, back-up copies and reporting of current events
<b>Scope of protection</b>	Defined by the sign and the goods and services classes	Defined in the patent claims	Defined by the representation	Defined by the specific work; plus performance, fixation and broadcast
<b>Period of protection</b>	10 years (indefinitely renewable)	Max. 20 years	5 years (renewable thereafter 4 x 5 years up to a maximum of 25 years)	70 years after the death of the author (50 years for computer programs); 50 years from the taking of a photograph without individual character
<b>Indications of protection</b>	<ul style="list-style-type: none"> <li>® = registered trade mark</li> <li>™ = trade mark</li> </ul> Use optional, misuse punishable by law	+pat+; pat. pend. (patent pending) Use optional, misuse punishable by law	mod. dep. Use optional, misuse punishable by law	©, "Copyright", "All rights reserved", "Tous droits réservés" or similar Use optional
<b>Application fees (CH)</b>	CHF 450, e-discount: CHF 100	CHF 200 (for the application) CHF 500 (optional search) CHF 500 (examination)	CHF 200 (basic fee) including publication of one representation	None
<b>Renewal fees (CH)</b>	CHF 700 (10 years)	CHF 100 for the 4 <sup>th</sup> year, after which the fee increases annually up to CHF 960 for the 20 <sup>th</sup> year	CHF 200 (5 years)	None
<b>Unique to Switzerland</b>	Infringement of earlier IP rights not examined for (trade mark search recommended)	Novelty and inventive step not examined for (prior art search recommended)	<ul style="list-style-type: none"> <li>Publication can be deferred for up to 30 months</li> <li>Novelty not examined for</li> </ul>	Collecting societies: SUISA, SUISSIMAGE, ProLitteris, SSA, SWISSPERFORM

<sup>1</sup> Copyright law also regulates the related rights of performing artists, producers of audio and audio-visual media, and broadcasting organisations.

### Period of protection

Inventions can be protected for a maximum of 20 years beginning from the date of the patent application. In order to maintain protection, the owner must pay annual fees from the fourth year following the date of filing.

### Filing in Switzerland

Do you want to patent your invention? Then send us a written patent application or apply by email (patent.admin@ekomm.ipi.ch). Application forms can be downloaded from [www.ipi.ch/download-en](http://www.ipi.ch/download-en). The complete application includes a description of the invention, at least one patent claim that defines the scope of protection, and illustrations where appropriate.

A patent attorney can help to analyse an invention for its essential features and to complete the application. The patent application is published on [www.swissreg.ch](http://www.swissreg.ch) 18 months after filing and the patent following its granting.

### Is the invention really new and inventive?

As we do not examine for these criteria, we recommend that you make sure that your invention fulfils these criteria for protection before applying for a patent, either by yourself or with the help of a specialist (p. 38). An initial overview of the latest technical status relating to your invention can be obtained with an "Assisted Patent Search". If you have already filed a patent for your invention, you can request that a Swiss Patent Application Search is carried out to determine if your invention is new and inventive. You can find further information on patent searches at [www.ipi.ch/patent-searches](http://www.ipi.ch/patent-searches).

### Protection in other countries

There are three ways to obtain a patent in other countries:

- **Filing directly to the country concerned**

Be aware that the legal basis, filing formalities as well as examination and granting procedures vary from country to country.

- **European applications**

Protection can be requested in almost 40 European countries including Switzerland with one single application process. A European patent can be applied for either directly through the European Patent Office in Munich (EPO, [www.epo.org](http://www.epo.org)) or through us for companies based in Switzerland or Liechtenstein.

### Did you know?

- File first, then talk! An invention that has already been made public in any form before the first application is not patentable.
- A patent does not protect the owner from having his invention used without his consent. However, it gives him the right of proceeding legally against such a use.
- Patents secure investments in research and development. As patent information is made public in return for the granting of a patent, patents also serve to disseminate knowledge. In this way, patent protection also promotes research and technological progress.

- Inventions which are created within the scope of an employment contract belong to the employer (under Art. 332 of the Swiss Code of Obligations) provided that nothing else has been agreed upon.
- The Patent Act applies to both Switzerland and Liechtenstein. Both countries form a single area of protection.

- **International applications**

The World Intellectual Property Organization (WIPO, [www.wipo.int](http://www.wipo.int)) in Geneva offers an international patent application process which is based on the so-called Patent Cooperation Treaty (PCT). Thanks to the PCT procedure, an invention is considered as being filed in more than 150 contracting states with only one single application. Such an application does not directly lead to a patent, but it will be independently examined in all of the designated countries subsequent to international procedural steps. The advantage of this process is that the applicant has more time to decide in which countries he would like to protect his invention. Costs are therefore incurred in the individual countries at a later date.

The **fees for patenting** an invention are dependent on the application process chosen and the number of countries in which protection has been requested. Costs for the translation of the patent specifications, if applicable, must also be taken into consideration.

We recommend that you discuss patent protection abroad and the best filing strategy with a patent attorney (p. 38).

**Alternatives to patent protection**

- You can keep the invention a secret (a trade secret), for example if it is not conceivable from the finished product.
- In industries with very fast development cycles, patent protection is maybe not necessary as by the time competitors have copied the product, you will already be bringing the next product generation to the market.
- If you do not want to protect your invention but at the same time want to prevent third parties from patenting it, you can make your invention public. In this way, it is no longer considered novel and therefore not patentable. If you want to publish your invention on the internet, you must ensure that the publication date can be proved at a later date. You can find an up-to-date list of service providers who can help you with this at [www.ipi.ch/defpub](http://www.ipi.ch/defpub).



## Designs – Protecting aesthetic creations

### What is a design?

In the legal sense, design is understood to be the exterior form of a product or parts of it. It can be either two-dimensional (a pattern) or three-dimensional. Its form is characterised by the arrangement of lines, contours, colours and surfaces or by the material used.

Examples include the design of consumer items such as cutlery and toothbrushes, industrial designs such as locomotives or production facilities, or detail designs such as watch faces, fabric patterns, or parts of the body of a vehicle.

### Why protect designs?

The design of a product appeals to our senses, evokes emotion and creates identification. This is why design has become one of the most crucial market factors and why counterfeiting is subsequently a frequent occurrence in this field.



### What are the practical advantages?

Owners of a design right can prevent others from using products with the same or a similar design. “Using” means in particular the manufacturing, storing, offering, putting on the market, importing, exporting or transiting of such products as well as simply being in possession of them. The import, export and transiting of commercially produced goods can also be prohibited if they are for private use.

### No protection

Designs which cannot be protected are those which are exclusively a result of the technical realisation of a function (for example, the threads on a screw) or which violate a federal law (such as the protection of coats of arms), treaties, or public morality and public order.

### Period of protection

A design can be protected for a maximum of 25 years (five terms of five years each). The period of protection begins on the day of filing the application.

### Applying in Switzerland

Do you want to register your design? Then submit a design application to us. Application forms can be downloaded from [www.ipi.ch/download-en](http://www.ipi.ch/download-en). You can also register your design by email to [design.admin@ekomm.ipi.ch](mailto:design.admin@ekomm.ipi.ch). The registration should contain at least one illustration of your design suitable for reproduction. Following registration, the design will be published on [www.swissreg.ch](http://www.swissreg.ch).

### Criteria for protection

Designs can be protected when:

- The design is new, which is the case when no other identical or similar design has been published before filing the application; and
- The design is sufficiently different from existing designs in major characteristics.



### Protection in other countries

Designs can be registered in other countries in two ways.

- **Applying directly to the country concerned**

Be aware that the legal basis, filing formalities as well as examination and granting procedures vary from country to country.

- **Several countries with one application**

At the World Intellectual Property Organization (WIPO, [www.wipo.int](http://www.wipo.int)) in Geneva for countries that are members of the Hague Agreement. At the European Union Intellectual Property Office (EUIPO, <https://euiipo.europa.eu>) in Alicante, Spain, for the whole European Union area.

We recommend that you discuss design protection abroad and the best filing strategy with a specialist (p. 38).

### Alternatives to design protection

A design can also fall under the protection of copyright or be protected as a trade mark (three-dimensional figurative mark) provided that the requirements for copyright or trade mark protection have been fulfilled.

#### Did you know?

- If you do not want your filed design to be published yet, for example to prevent competitors from identifying trends, you can postpone its publication for up to a maximum of 30 months.
- Protection is independent of the dimensions i.e. a scale model enjoys the same protection as the original. This is why no measurements should be given in the illustrations.



## Copyright – Taking the stage for artists

### What is copyright?

Copyright protects the authors of literary and artistic works. It protects the form and not the content. Therefore, it is the way in which an idea is expressed that is protected, and not the idea or concept itself. For example, Albert Einstein's essay, "The Foundation of the General Theory of Relativity" in the "Annals of Physics" is protected by copyright. The theory of relativity itself, however, may be freely used or described, simply not using the same words as in Einstein's original text.



### What are the practical advantages?

The copyright owner can determine whether, when and how his work may be used. In particular, he has the following rights:

- **Right of reproduction:** The right to reproduce the work in any way (manufacture of further copies of the work); whether the original work has been changed or not is irrelevant.
- **Right to distribute:** The right to offer the work, to sell it or to put it into circulation in any other way.
- **Right to make available to the public:** The right to make the work available through a communication network such as the internet so that the public has access to it and the work can be downloaded, for example.
- **Right to perform and present:** The right to publicly recite, perform or to make perceivable in any other way.
- **Right to adapt:** The right to decide whether, when and how a work shall be adapted and whether it may be used as the basis for the creation of a new work (e.g. a translation).

### What are works?

Works in terms of copyright are creations in the field of art and literature. In particular, these include:

- Literary works of any kind (texts) from novels, scientific papers and newspaper articles to marketing brochures and website texts;
- Visual and audio-visual works such as photographs and films;
- Works of music and other acoustic works;

### Criteria for protection

Works are protected by copyright provided that they:

- Belong to the field of art and literature;
- Are the result of intellectual creation; and
- Have individual character (photographs without individual character are also protected).

The purpose, the effort or the financial means used to create a work are not relevant.

In individual cases, it is incumbent on the courts, however, to make a binding decision on whether the criteria for protection have been fulfilled.

- Works of visual arts (paintings, sculptures, graphics) as well as applied art (artistic objects with practical value), whereby an application for a design does not exclude copyright protection;
- Works with scientific or technical content such as drawings, plans, maps or sculptural representations;
- Architectural works.

### Protecting software

The source code of computer programs, in particular, is protected by copyright. Problem-solving principles, however, i.e. algorithms on which software is based, are not protected by copyright.

### No protection

Copyright does not protect ideas, achievements, concepts or instructions – even if they are individual. Laws, ordinances and other official texts as well as decisions, protocols and reports by authorities and public administrations are also not protected if they concern the rights of citizens. Means of payment, patent specifications and published patent applications are also not protected by copyright.

### Period of protection

In Switzerland, copyright protection expires 70 years after the date of death of the author (50 years for computer programs). For photographs without individual character, they are no longer protected by copyright after 50 years of being taken.

### Automatic protection

Copyright protection begins the moment a creation comes into existence. Neither formalities nor any registration are required.

### Related rights

In addition to creative works, copyright law also protects other categories of cultural providers. Actors, musicians, music and film producers as well as radio and television programmes are also protected. This protection does not go as far in detail as that for authors, however.

### Protection in other countries

In principle, every legal system is always national. Swiss copyright protects authors and other categories of cultural providers (related rights) in Switzerland only. International protection is regulated by international agreements such as the Bern Convention, the WIPO Copyright Treaty, the WIPO Performances and Phonograms Treaty, the Rome Convention as well as others.

### Did you know?

- The private use of published works is permitted (for example, in a private circle of friends and family, extracts for teaching purposes in school or reproduction of extracts for informational purposes in a company). In some cases, however, the author has a right to remuneration.
- It is not permissible to add third-party music to personal videos and disseminate them via social media platforms. That would go beyond private use, so permission is needed to include music.

- If a software program runs on more than one computer, a licence is required for each computer.
- References on the work such as “Copyright”, “All rights reserved” or “©” are not necessary for protection in Switzerland but can provide useful indications to others and even serve as a warning sign in certain instances. The person whose name is on the work or who is named in the publication is usually recognised as the author.
- Derived works such as translations, film screen adaptations or musical arrangements (cover versions) are also protected.

### Collecting societies

Collecting societies collectively administrate the rights of copyright owners, particularly where collecting royalties by the individual rights owner is not possible or does not make sense (for example, use within a school, reproduction within a company, DVD rentals or private copies onto blank CDs).

- SUISA for musical, non-theatrical works – [www.suisa.ch](http://www.suisa.ch)
- SUISSIMAGE for audio-visual works – [www.suissimage.ch](http://www.suissimage.ch)
- ProLitteris for literature, photographs and art – [www.prolitteris.ch](http://www.prolitteris.ch)
- SSA, the Swiss authors' society for dramatic works, musicals and audio-visual works – [www.ssa.ch](http://www.ssa.ch)
- SWISSPERFORM for related rights – [www.swissperform.ch](http://www.swissperform.ch)

- Works that are permanently located on publicly accessible grounds may be reproduced two-dimensionally (i.e. it is not necessary to obtain the owner's permission in order to photograph a statue in a public place and then commercially use this photo, for example).
- The quoting of a published work in another work is generally permitted, provided that the quotation serves as an explanation, illustration or reference. Quotations must be marked as such and the source clearly indicated. A good rule of thumb is: as little as possible, but as much as necessary.

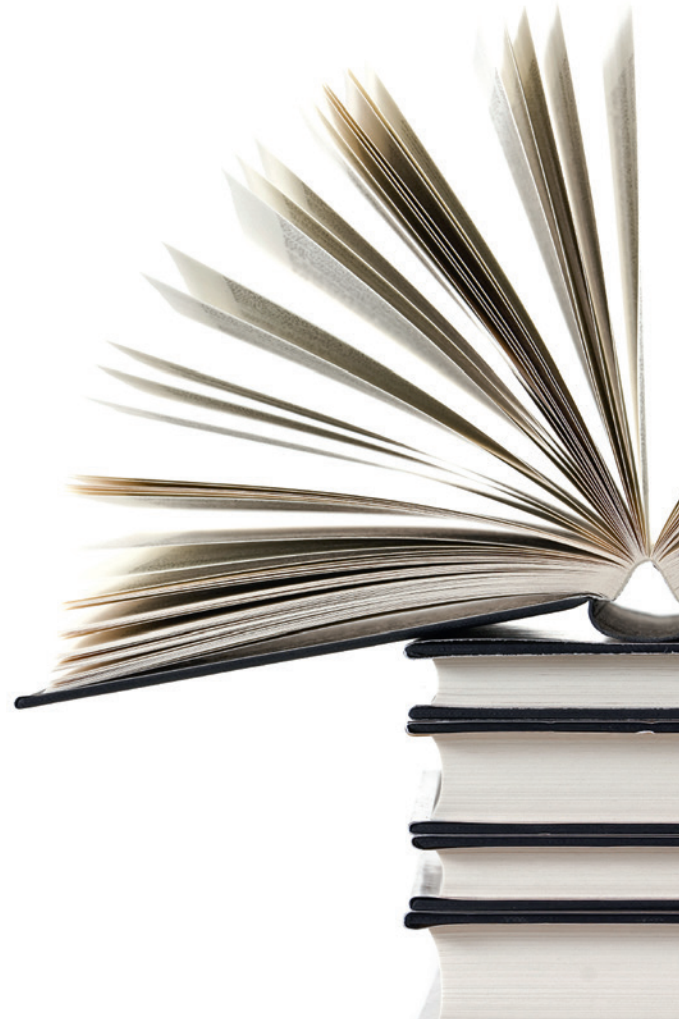

## Patent attorneys and trade mark consultants

With their natural science or scientific engineering degree, as well as their secondary training in patent and design law and other areas of intellectual property (IP), patent attorneys operate as experienced interpreters between law and technology. They advise and support in all steps from the recognition of the invention to the enforcement of a patent against others, not only in Switzerland but internationally too.

Trade mark consultants offer support in all questions concerning trade mark protection. This mostly concerns the clarification of the availability of a trade mark and accordingly the similarity with existing trade marks, questions on the use of a trade mark, and an assessment of possible conflicts. They also help to defend trade mark rights.

Patent attorneys and trade mark consultants represent the applicant of an IP right before the patent and trade mark offices, either directly or, in the case of foreign national offices, through domiciled representatives whom they know well. They monitor and administrate IP rights, write infringement and validity opinions, develop IP strategies, and advise on the licensing and sale of IP rights.

For a free first consultation on questions concerning patent protection, the IP Advisory Network is available to SMEs and individuals in Switzerland and Liechtenstein. You can find participating patent attorneys in your area and the addresses of their chambers at [www.ipi.ch/ip-net](http://www.ipi.ch/ip-net).

## The Swiss Federal Institute of Intellectual Property

The Swiss Federal Institute of Intellectual Property (IPI) is the federal government's central point of contact for all questions concerning patents, trade marks, geographical indications of source, design protection and copyright. We provide you with the following services:

- **Granting of IP rights:** You can apply to register trade marks, patents and designs with us – for both Switzerland and, depending on the process, internationally. We examine national applications, grant IP rights and administer the corresponding registers.
- **Patent and technology searches:** We provide various search services from an assisted patent search for beginners to complex patent infringement searches.
- **Information and training:** Our tasks also include informing companies about how they can use the IP rights system and the scope for development available to them for their commercial success. We hold courses and seminars and cooperate with Swiss schools of higher education.

We advise the federal authorities on all questions concerning intellectual property and are responsible for the internal administrative preparation of the relevant legislation. We represent Switzerland in the relevant international organisations as well as in negotiations on intellectual property with third countries.

The IPI is its own legal entity and is independent from the federal government budget. Today, it employs over 300 members of staff.



### **Do you have any other questions?**

The IPI Contact Centre with the number **+41 31 377 77 77** is at your disposal, free of charge, to answer your questions on protecting innovations and creations:

Monday to Friday from 8am to 12pm and 1pm to 5pm.

You can also contact the IPI Contact Centre by email at [info@ipi.ch](mailto:info@ipi.ch).

### **Online information**

Our website also includes:

- Information especially for SMEs ([sme.ipi.ch](http://sme.ipi.ch))
- Brochures and forms ([www.ipi.ch/download-en](http://www.ipi.ch/download-en))
- A list of trade mark consultants and patent attorneys in Switzerland ([www.ipi.ch/tm-consultants](http://www.ipi.ch/tm-consultants) and [www.ipi.ch/pat-attorneys](http://www.ipi.ch/pat-attorneys))
- A list of patent attorney offices affiliated to the IP Advisory Network (free first consultation) ([www.ipi.ch/ip-net](http://www.ipi.ch/ip-net))
- Information on patent and trade mark searches ([www.ipi.ch/patent-searches](http://www.ipi.ch/patent-searches) and [www.ipi.ch/trademark-searches](http://www.ipi.ch/trademark-searches))
- Information on our training opportunities, courses and customised “à la carte” seminars for companies, associations and chambers of commerce ([www.ipi.ch/training](http://www.ipi.ch/training))
- Information on the current and future legal situation, as well as on new national and international developments in the field of intellectual property ([www.ipi.ch/legalinfo](http://www.ipi.ch/legalinfo))

# The IPI – the experts for questions about trade marks, patents and designs

## An overview of our services

- All about intellectual property: our SME portal  
[www.ipi.ch/sme](http://www.ipi.ch/sme)
- Inventions under the microscope: our Assisted Patent Search  
[www.ipi.ch/assistsearch](http://www.ipi.ch/assistsearch)
- Tailor-made courses: practical knowledge from our experts  
[www.ipi.ch/training](http://www.ipi.ch/training)
- On the ball: our Contact Center  
031 377 77 77

[www.ipi.ch](http://www.ipi.ch)

.....  
**Eidgenössisches Institut für Geistiges Eigentum**  
.....  
**Institut Fédéral de la Propriété Intellectuelle**  
.....  
**Istituto Federale della Proprietà Intellettuale**  
.....  
**Swiss Federal Institute of Intellectual Property**  
.....